

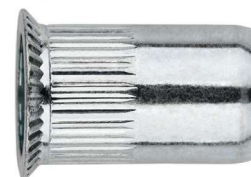

TRCA



TRCR



TRAV

CHARACTERÍSTICS

- Mechanical characteristics and quick installation offer great advantages in economic terms and reduced assembly time.
- Quick installation: 2 – 4 seconds.
- Blind rivet nuts: installation is carried out on only one side of the assembly, ideal for pipe work and joints or unions with zones without internal access.
- Available in a wide range of diameters and sizes.
- The knurled body improves the resistance to rotation in soft materials such as aluminium and galvanic continuity improvement in metal sheets.

APPLICATIONS

- Alternative to traditional assembly methods such as screws, bolts, washers, etc.
- May be installed in threaded materials.
- May be installed in plastic and metallic materials.
- See web data sheet:



BASE MATERIAL



Aluminium woodwork

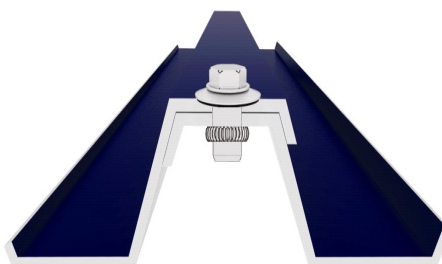

Plate assembly



Profile plate metal

APPLICATION EXAMPLES



1. RANGE

ITEM	CODE	PHOTO	MATERIAL	COATING
1	TRCA		Steel C4C UNE-EN 10263-2 (1.0303), zinc-plated $\geq 5 \mu\text{m}$	
2	TRCR		Steel C4C UNE-EN 10263-2 (1.0303), zinc-plated $\geq 5 \mu\text{m}$	
3	TRAV		Steel C4C UNE-EN 10263-2 (1.0303), zinc-plated $\geq 5 \mu\text{m}$	

2. INSTALLATION PROCEDURE

1. Select the suitable Rivet nut based on load to be applied, the sizes of the bolt to be installed, base material thickness and the type of application.
2. Drill the diameter specified in the table (observe tolerance).
3. Install the rivet nut.
4. Place the material to be fixed.
5. Insert the shank of the riveting tool reaches the end. (Fig. 1)
6. Smoothly screw in until the riveting tool reaches the end (Fig. 2).
7. Firmly screw in without exceeding the indicated torque in the table section 6 (Fig. 3).
8. Unscrew the tool shaft and the nut will be installed. (Fig. 4).

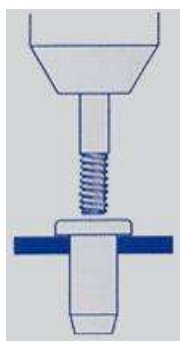

Fig.1

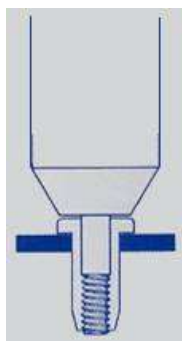

Fig.2

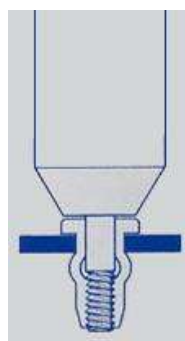

Fig.3

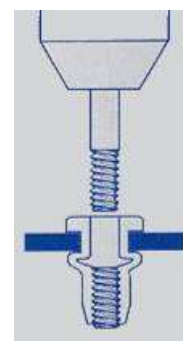
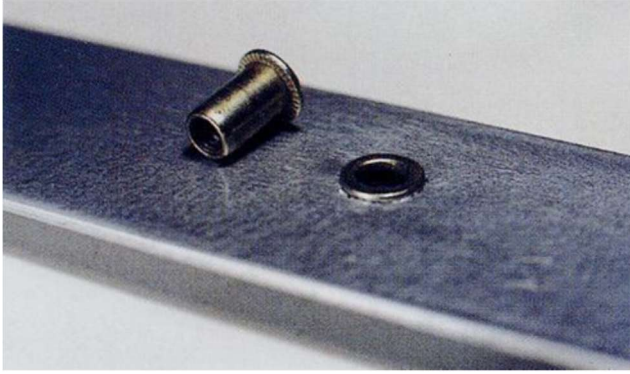

Fig.4



RIVETING GUNS



1. TRCA

Rivet nut wide head

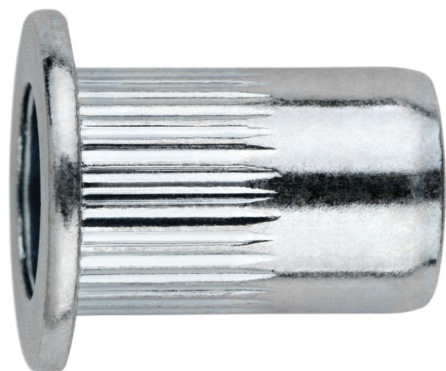

Properties



Steel

Coating: zinc-plated $\geq 5 \mu\text{m}$

Main applications

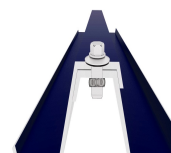

Aluminium woodwork

Plate assembly

Profile plate metal

1.1 CHARACTERISTICS AND ADVANTAGES

- Provides a big bearing area under the head to distribute efforts.
- Extremely versatile.
- Reinforces the hole and prevents thrust fault.
- Head can be used as a spacer.
- Possibility of using seal.
- To be used in metallic sheets or softs materials in high strength.

1.2 DATA

CODE	Metric	L Length [mm]	ØD head [mm]	Ød body [mm]	S Lip thickness [mm]	Fixture thickness [mm]	Ø Pilot hole [mm]
TRCA0310	M3	10	6,5	4,9	1,0	0,5 ÷ 3,0	5
TRCA0410	M4	10	8,5	5,9	1,1	0,5 ÷ 3,0	6
TRCA0411		12				3,1 ÷ 4,0	
TRCA0512	M5	12	9,5	6,9	1,1	0,5 ÷ 3,0	7
TRCA0515		15				3,1 ÷ 6,0	
TRCA0614	M6	14,5	12,5	8,9	1,6	0,5 ÷ 3,0	9
TRCA0616		17,5				3,1 ÷ 6,1	
TRCA0816	M8	16	15,5	10,9	1,6	0,5 ÷ 3,0	11
TRCA0818		19				3,1 ÷ 5,5	
TRCA1017	M10	17	18,5	12,9	2,1	1,0 ÷ 3,5	13
TRCA1022		22				3,5 ÷ 6,0	
TRCA1223	M12	23	22,5	15,9	2,1	1,0 ÷ 4,0	16

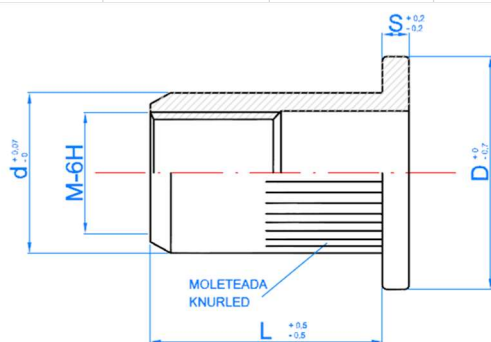

MECHANICAL PROPERTIES
RECOMMENDED LOAD

Metric	Tensile	Shear*	Torque
[-]	[kN]	[kN]	[Nm]
M3	4	0,98	1,2
M4	6,8	1,66	3
M5	10	2,74	6
M6	15	3,43	10
M8	27	4,41	24
M10	37	4,9	48
M12	54	6,86	82

* The value of shear varies depending on surface, dimension and material of screws.

2. TRCR

Rivet nut reduced head

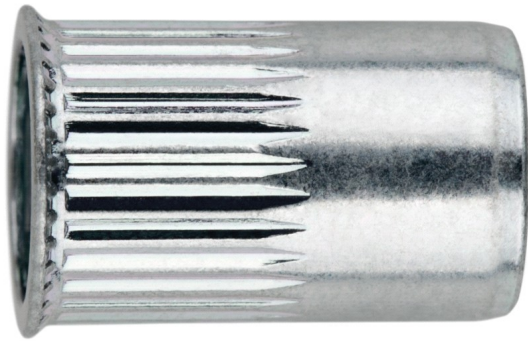

Properties



Steel



Coating: zinc-plated $\geq 5 \mu\text{m}$

Main applications



Aluminium woodwork

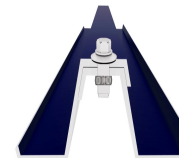

Plate assembly



Profile plate metal

2.1 CHARACTERISTICS AND ADVANTAGES

- Provides a bigger bearings area under the head.
- To be used in soft or brittle materials to be assembled in rigid material-
- Flat finished without protrusions on thin sheets with low loads (for example, appliances or bodywork).

2.2 DATA

CODE	Metric	L Length [mm]	ØD head [mm]	Ød body [mm]	S Lip thickness [mm]	Fixture thickness [mm]	Ø Pilot hole [mm]
TRCR0410	M4	10	6,5	5,9	0,5	0,5 ÷ 3,0	6
TRCR0511	M5	11,5	7,5	6,9	0,5	0,5 ÷ 3,0	7
TRCR0614	M6	14	9,5	8,9	0,5	0,5 ÷ 3,0	9
TRCR0815	M8	15,5	11,5	10,9	0,5	0,5 ÷ 3,0	11
TRCR1019	M10	19,5	13,5	12,9	0,7	0,5 ÷ 3,5	13

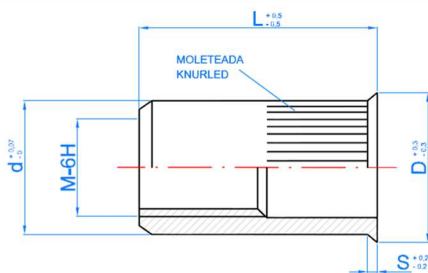

MECHANICAL PROPERTIES
RECOMMENDED LOAD

Metric	Tensile	Shear*	Torque
[-]	[kN]	[kN]	[Nm]
M4	6,8	1,56	3
M5	10	2,15	6
M6	15	2,35	10
M8	27	2,84	24
M10	37	4,21	48

* The value of shear varies depending on surface, dimension and material of screws.

3. TRAV

Rivet nut countersunk head

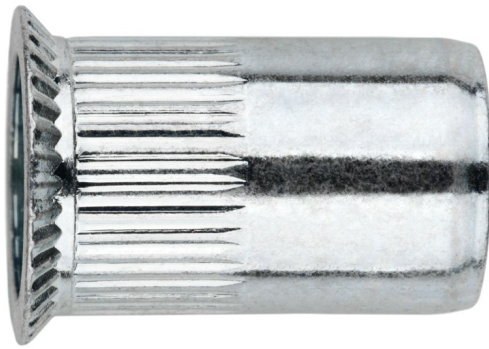

Properties



Steel



Coating: zinc-plated $\geq 5 \mu\text{m}$

Main applications



Aluminium woodwork

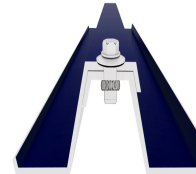

Plate assembly



Profile plate metal

3.1 CHARACTERISTICS AND ADVANTAGES

- To be used when a flat surface is needed.
- For bigger fixing thickness.
- Flat finished without protrusions on thin sheets with low loads (for example, appliances or bodyworks)

3.2 DATA

CODE	Metric	L Length [mm]	ØD head [mm]	Ød body [mm]	S Countersinking thickness [mm]	Fixture thickness [mm]	Ø Pilot hole [mm]
TRAV0411	M4	11,5	8,5	5,9	1,5	1,5 ÷ 3,5	6
TRAV0513	M5	13,5	9,5	6,9	1,5	1,5 ÷ 4,0	7
TRAV0616	M6	16	11,5	8,9	1,5	1,5 ÷ 4,5	9
TRAV0819	M8	19	13,5	10,9	1,5	1,5 ÷ 4,5	11
TRAV1021	M10	21	15,5	12,9	1,5	1,5 ÷ 4,5	13

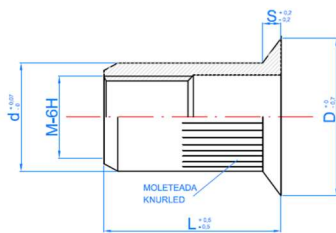

**MECHANICAL PROPERTIES
RECOMMENDED LOAD**

Metric	Tensile	Shear*	Torque
[-]	[kN]	[kN]	[Nm]
M4	6,8	2,15	3
M5	10	2,25	6
M6	15	3,62	10
M8	27	4,7	24
M10	37	5,19	48

* The value of shear varies depending on surface, dimension and material of screws.